



DATE: 26/03/2019

MODEL: SR1

SR1 SETUP HANKOOK 2019

PRIORITY – HIGH (ACTION)

For the 2019 season Hankook are able to supply a new and upgraded tyre for the SR1. The rear tyre (both wet and dry) has been upgraded with a taller profile (195/570/R13), this improves traction and helps stability under braking. The wet tyre option, both front and rear, has also been changed to a softer compound which improves wet performance.

Due to the change to the taller sidewall it is required that cars are fitted with the smaller rear damper eyelet (33mm).

Spacers fitted to the rear upright rose joint should be removed.

The rear sprocket needs to be changed to a 46 tooth sprocket, along with the correct length chain (35links - one removed from new).

The required components are listed below:

Rear Damper Eyelet: **SS0207 (x2)**

Rear Sprocket: **TC0034**

Chain: **TC0013**

Radical has put together a kit for these parts: **EK0006 – 2019 Hankook Tyre Upgrade Kit**

To help with the swap over this kit is being subsidised by Radical to the reduced cost price of **£127.50**

The recommended baseline setup using these parts is shown on the following page.

For parts supply please contact: stores@radicalsportscars.com

Technical Department
Radical Sportscars

Mobile: +44 (0)7876 146854
Tel: +44 (0)1733 331616 ext. 263
Email: technical@radicalsportscars.com



RADICAL



SR1 - Factory Setup Sheet 2019 - Hankook

Note: When carrying out set-up on flat-patch, set tyre pressures to hot pressure. Ensure that they are returned to cold pressures after setup is complete.

Date		Chassis #		Driver	
Post Event		Pre Event		Technician	

Camber		
2.0	↑	2.0
3.0		3.0

Toes		
2mm Out	↑	2mm Out
2mm In		2mm In

Avo	Springs/Preload			Avo
+10	Rate	FARB	Rate	+10
	300	Soft 15.8mm	300	
		Medium 19mm		
	Length	Hard 22.2mm	Length	
	7"	↑	7"	
	Preload		Preload	
	4		4	

Ride	Front Diffuser H	Ride
70m m	50m m	70m m
	Ballast Weight	
Drop		Drop
156m m	Cross%	156m m
Weight	Total weight	Weight
kg	kg	kg

Avo	Springs/Preload			Avo
+4	Rate	RARB	Rate	+4
	250	Soft 12.7mm	250	
		Medium 15.8mm		
	Length	Hard 19 mm	Length	
	7"	↑	7"	
	Preload		Preload	
	0		0	

Ride	Rake m m		Ride
70m m	0		70m m
Drop	↑		Drop
165m m			165m m
Weight	LHD	RHD	Weight
kg			kg

Tyre Pressure (PSI) (Cold & Hot)			
22	Hankook	22	PADS
16	↑	16	08
22		22	PADS
15		15	08

Fuel Level
-

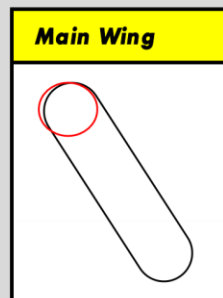

Comments: 48mm Front Eyelet, 33mm Rear Eyelet, No Spacers Fitted, 46T Rear Sprocket (Chain: one link removed from new) Rear Drop Heights measured with 4" bar. Front Drop Heights measured with 2" bar.

FRONT TYRES:

2017 (Dunlop Treaded)		2018 (Hankook Treaded)		2019 (Hankook Treaded)	
Part Number	Size	Part Number	Size	Part Number	Size
WR0017	160/535/R13	WR0027	160/530/R13	WR0027	160/530/R13
2017 (Dunlop Wet)		2018 (Hankook Wet)		2019 (Hankook Wet)	
Part Number	Size	Part Number	Size	Part Number	Size
WW0020	160/535/R13	WW0043	160/530/R13	WW0051	160/530/R13

REAR TYRES:

2017 (Dunlop Treaded)		2018 (Hankook Treaded)		2019 (Hankook Treaded)	
Part Number	Size	Part Number	Size	Part Number	Size
WR0018	170/575/R13	WR0028	195/530/R13	WR0032	195/570/R13
2017 (Dunlop Wet)		2018 (Hankook Wet)		2019 (Hankook Wet)	
Part Number	Size	Part Number	Size	Part Number	Size
WW0012	170/575/R13	WW0044	195/530/R13	WW0050	195/570/R13

FRONT DAMPER EYELETS:

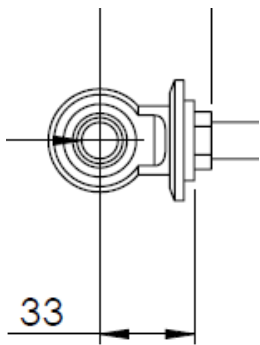
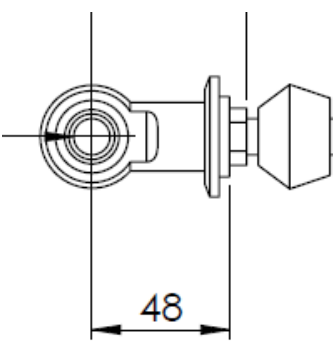
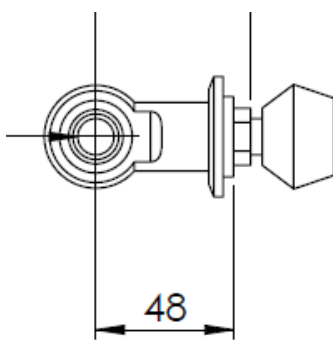
2017 (Dunlop)		2018 (Hankook)		2019 (Hankook)	
Part Number	Length	Part Number	Length	Part Number	Length
SS0207	33mm	SS0202	48mm	SS0202	48mm
					

REAR DAMPER EYELETS:

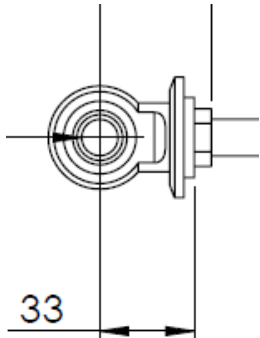
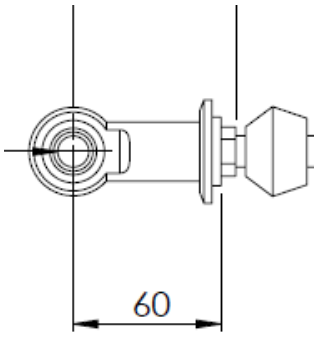
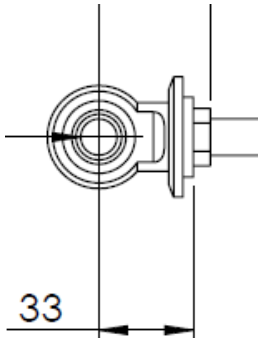
2017 (Dunlop)		2018 (Hankook)		2019 (Hankook)	
Part Number	Length	Part Number	Length	Part Number	Length
SS0207	33mm	SS0203	60mm	SS0207	33mm
					

REAR SPROCKET:

2017 (Dunlop)		2018 (Hankook)		2019 (Hankook)	
Part Number	Number of Teeth	Part Number	Number of Teeth	Part Number	Number of Teeth
TC0034	46T	TC0053	43T	TC0034	46T

CHAIN:

2017 (Dunlop)		2018 (Hankook)		2019 (Hankook)	
Part Number	Links Removed	Part Number	Links Removed	Part Number	Links Removed
TC0013	1	TC0013	2	TC0013	1